

Washroom Partitions



Installation Guide

This guide provides installation procedures for Washroom Partition Systems of standard dimensions. Installers should note that minor variations in components and assembly procedures may occur from state to state because of local practices. Where further assistance is required, installers should contact ABP Allboards Pty Ltd.

Site Check & Preparation

Before commencing installation, check conditions on site.

- All preceding works are complete and satisfactory.
- Tiling has been allowed to set for a minimum of 48 hours.
- Dimensions have been checked.
- Adequate lighting and ventilation exists.
- Power supply is available
- Floor and wall planes are true. If out of plumb/level, dividers, frontals and end nibs may require trimming.

Installers should also:

- Obtain detailed drawings and materials list.
- Check materials list to goods received.
- Discuss the installation with the site supervisor to resolve any problems which may affect installation, or expose the partitions to damage by other trades.

Handling & Storage

Take care to ensure panels are not damaged prior to and during installation.

- Handle materials with care at all times to avoid damage and chipping.
- Ensure materials are delivered as close as practical to the work area.
- Carry all panels on edge.
- Store under cover.
- Stack panels on a flat surface and place protective material such as foam, cardboard or plastic sheeting between prepainted panels.

General Checklist

- ✓ Check for pipes and electrical wiring before commencing installation.
- ✗ DO NOT use a hammer drill on HardiColor panels.
- ✓ Use only masonry drill bits when drilling HardiColor panels.
- ✓ Use a depth gauge for drilling blind holes.
- ✓ Insert all pop rivets to inner side of frontals and nibs.
- ✓ To fix partitions to Villaboard Drywall, use cavity anchors. (Not wallmates)
- ✓ Pedestal mounted installations are more stable if abutting a fixed wall.
- ✓ Cut edges should be touched up with the paint supplied, before installation.

Typical Assembly

Toilet Partitions

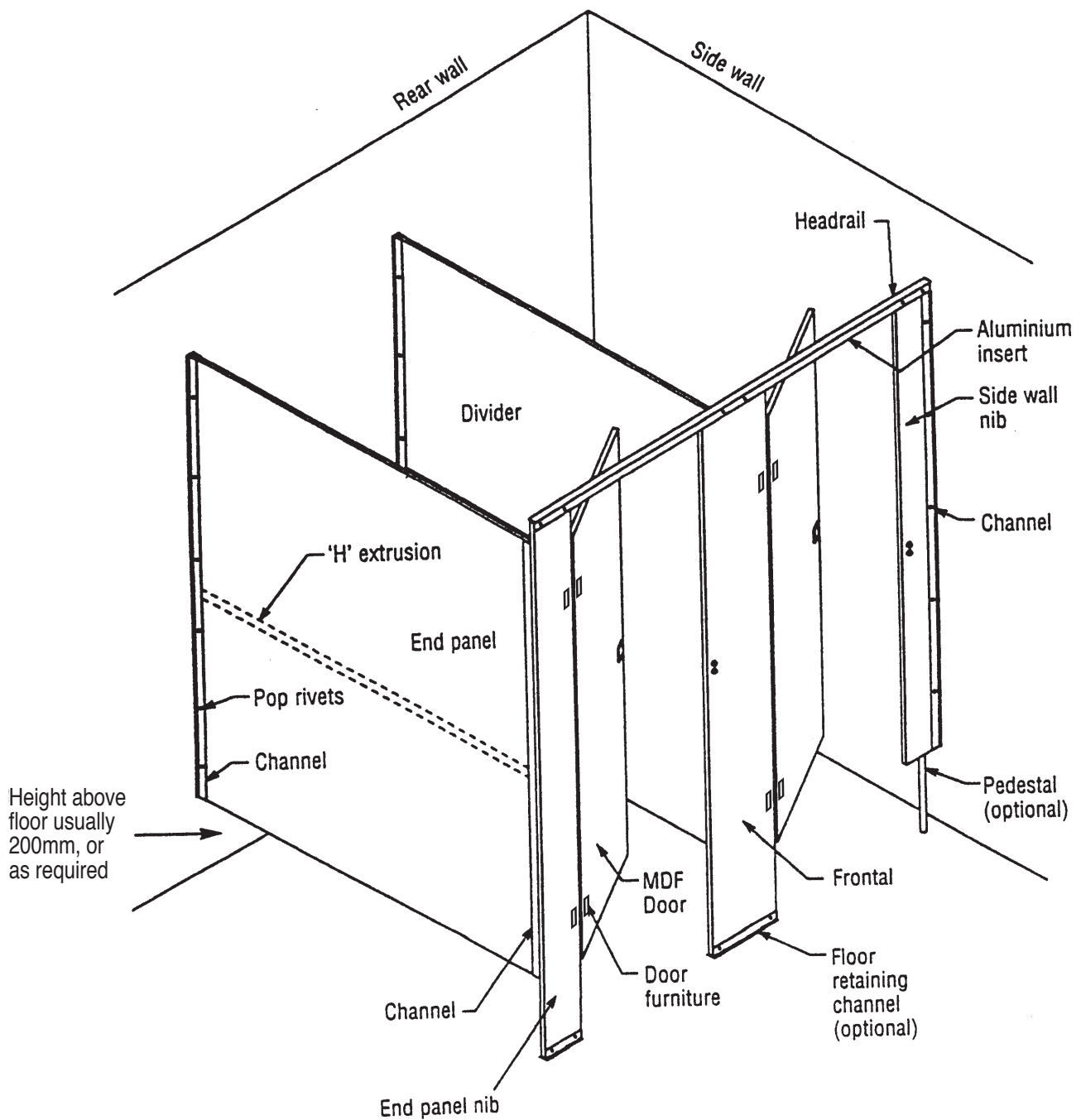

Typical Assembly

Shower Partitions

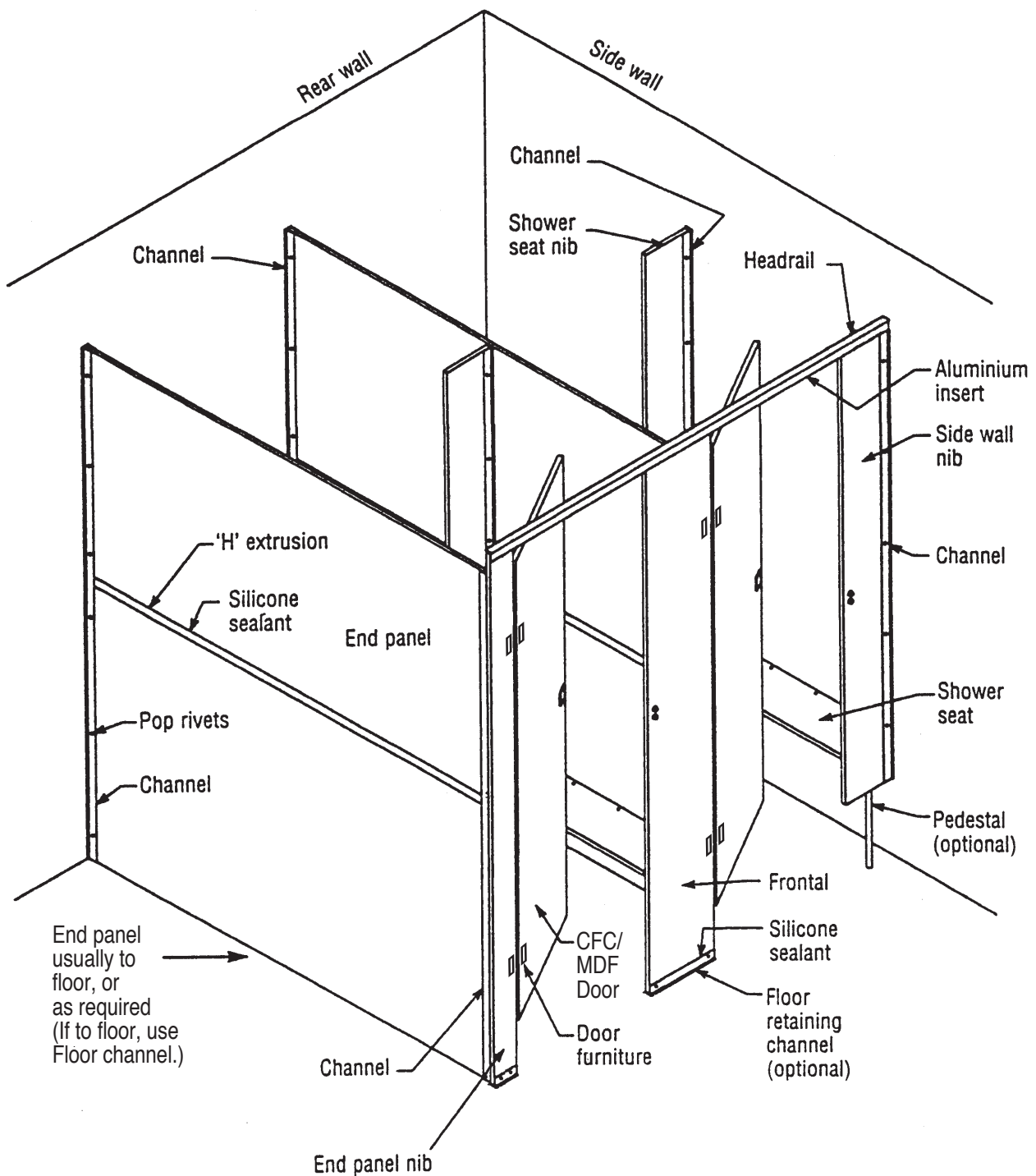

Typical Assembly

Typical toilet for the Disabled

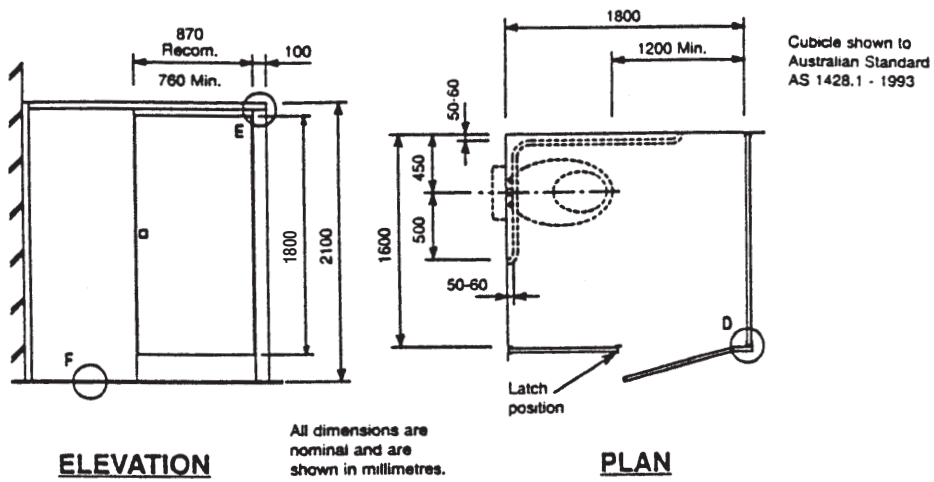

Fixing Details

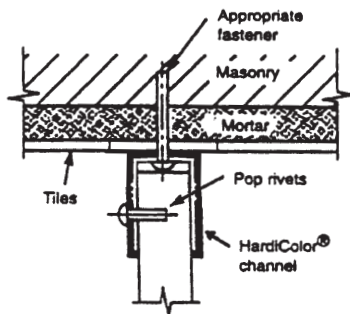

Divider to wall
(18 mm)

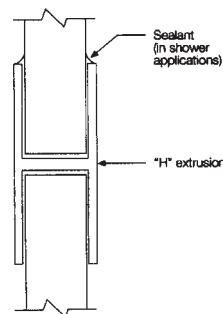

Two piece dividers
(18mm)

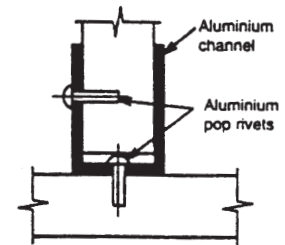

Divider to frontal
(18 mm)

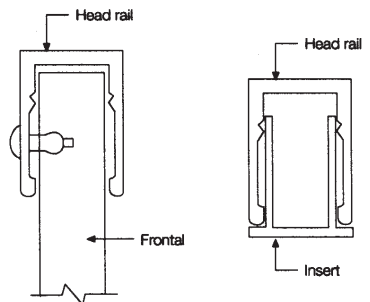

Head rail on frontal

Head rail showing
insert trim over door

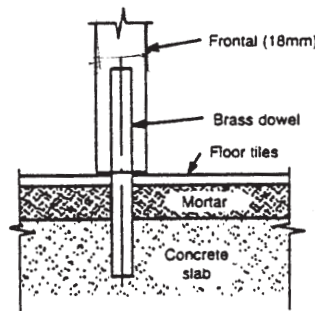

Frontal to floor—Pedestal
method

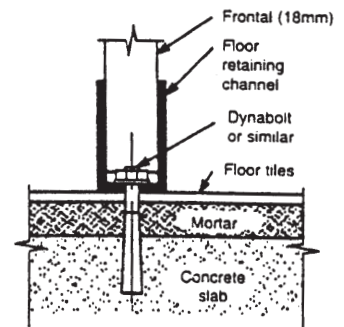

Frontal to floor—retaining
channel method

Floor Fixed Frontals

Retaining Channel Method

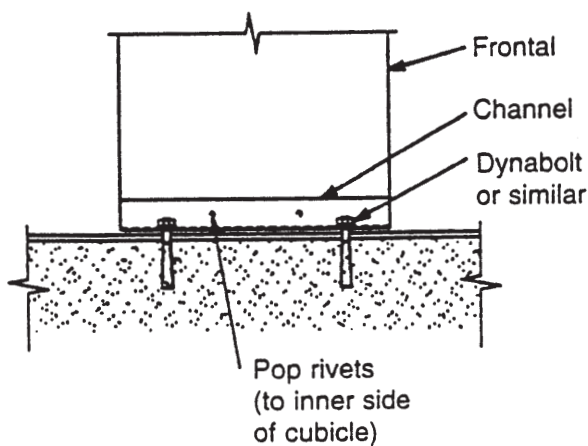

- Mark position of floor retaining channel on floor centre line.
- Measure and cut channel to length to suit frontal base.
- Fix channel to floor using 2 masonry anchors
- Install frontal into channel and fix on inside using 2 pop rivets.

Pedestal mounted frontals

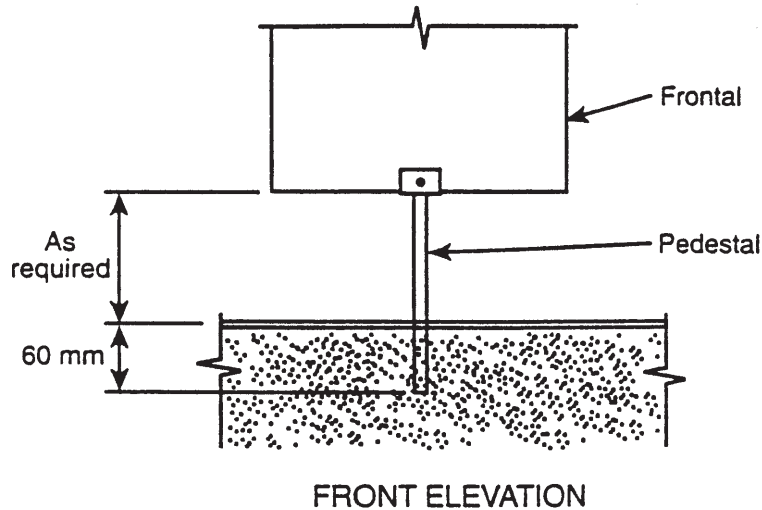

- Mark out pedestal hole position on floor centre line.
- Drill 25mm diameter pedestal hole in floor to a depth of 60mm minimum.
- Apply epoxy into hole and insert pedestal to correct height. Allow to set.
- Install frontal or divider onto pedestal and fix using chrome plated or stainless steel bolts with acorn nuts.

Note: T-pedestals should be used on frontals for maximum stability where possible.

Note: If installation into timber floors presents a problem, please contact ABP Allboards Pty Ltd.

Pedestal mounted divider

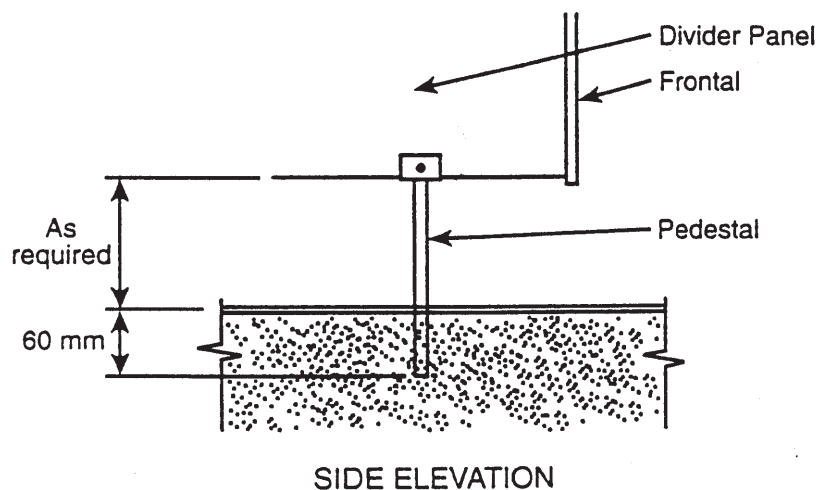

Fixing Details

Install divider panels

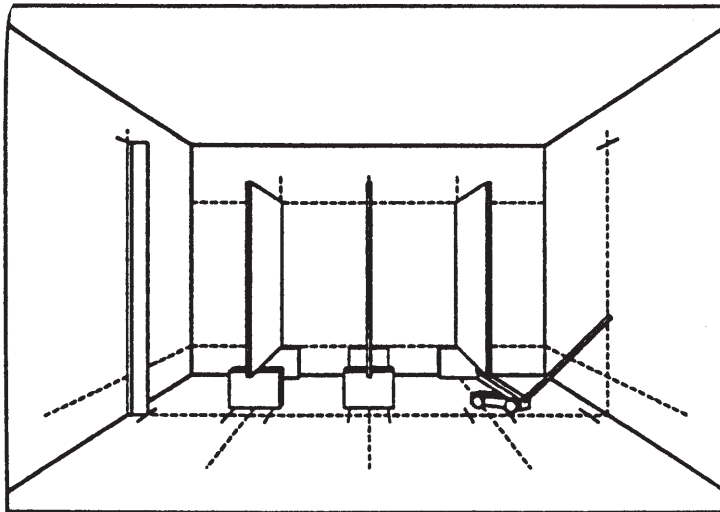

- Locate bottom dividers in rear wall channels and pack to level.
- On sloping floors trim floor mounted panels, nibs and frontals to suit.
- Cut 'H' extrusion to length (allowing for front and rear channels) and assemble.
- Locate top divider.
- Only install one divider at a time.

Install frontals

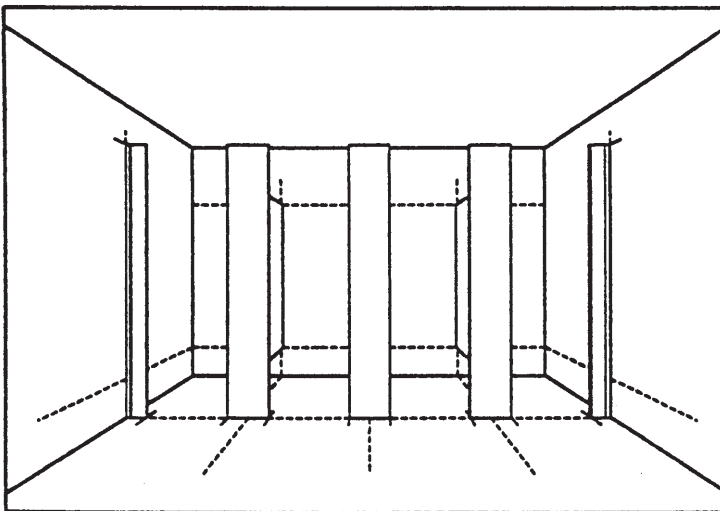

- If required, trim frontals to sit flush on a sloping floor.
- Fix bases of frontals using appropriate method (see 'Frontal Fixing Methods' on page 7 and 8).
- Ensure frontals are plumb and in line.
- Fix divider in rear and front channels using a minimum of 6 pop rivets each.

Install remaining dividers, frontals, nibs and doors

- Repeat until all dividers, frontals and nibs have been installed.
- Fit and install doors and door hardware.

Fixing Details

Install shower seat nibs and seats



- Mark out shower nib position on floor and divider side wall.
- Cut 18mm channels to length. Where nib is fixed to divider, notch the back of the channel to clear for 'H' extrusions.
- Fix channels to dividers or side walls.
- Fix nibs bases using floor retaining channel method only (see 'Frontal Fixing Methods' on page 7).
- Fix nibs into nib channels using a minimum of 6 pop rivets at 300mm centres.
- Cut, and fix shower seat retaining channel to nib, divider/side wall and frontal. Alternatively, use aluminium angle.
- Install shower seats and fix on underside with pop rivets.

Seal channels and extrusions

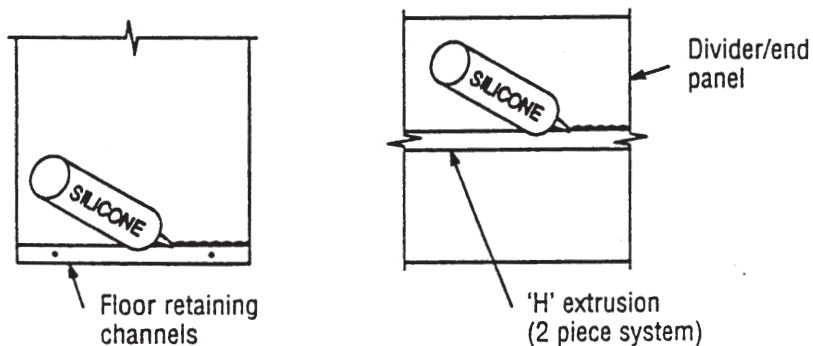

- Use an approved silicone sealant to seal all 'H' extrusions and floor retaining channels in showers and toilets.

Installing doors and door hardware

- Position indicator bolt and staple centrally, and hinges at equal distances from top and bottom of door, so that doors can be reversed if required.
- Hold hinges and other door hardware in place to mark position of holes on door and frontal.
- Drill holes on door and frontal. A masonry drill bit is best for drilling fibre cement material. (Do not use hammer setting).
- Fit hinges and door hardware.
- Fit door to frontal.

Note: Please take care when fitting door hardware. Follow hardware manufacture's instructions.

Installation

Warranty

The system recommended in this manual are intended to assist those interested in the specification and installation of HardiColor Washroom Partition Systems.

The successful installation of these systems depends on numerous factors outside the control of ABP Allboards Pty Ltd. However, the Company will accept responsibility for or in connection with the quality or suitability of the systems when installed in accordance with its written design recommendations.

ABP Allboards Pty Ltd ("the Company") also warrants goods supplied and installed by the Company for a period of 1 (one) year from date of practical completion against defects arising during normal use and caused by defects in materials supplied by, or the workmanship of employees of or contractors engaged by, the Company. This warranty does not cover any wilful or accidental damage caused by others to good installed by the Company.

If it is proven to the reasonable satisfaction of the Company that any goods supplied by the Company or any services performed by the Company are defective, then the Company will rectify the defect by (at the option of the Company):

- in the case of goods, the replacement, repair or payment for the cost of replacement or repair of such goods; or
- in the case of services, the supply of the services again or payment of the cost of having the services supplied again.

The Company does not accept liability for consequential losses or damages however they occur.

All warranties other than those specified by the Company are hereby excluded, and all conditions, obligations and liabilities however arising are hereby excluded. Nothing in this warranty, however, shall be construed as affecting any rights the buyer may have under the Trade Practices Act or any other Commonwealth or State Legislation which give the buyer rights which cannot be modified or excluded by agreement.

Please check with ABP Allboards Pty Ltd for confirmation of current issue.

Published February 2007. © Copyright ABP Allboards Pty Ltd. ABN 91 064 018 060



12 Mica Street
Carole Park, Brisbane, QLD 4300
PO Box 143, Carole Park, QLD 4300

P. 07 3271 5677
F. 07 3271 5688

E. info@abp-allboards.com.au
www.abp-allboards.com.au